

L70 Product Specifications

Parameter	Value	Units
Configuration & Physical Parameters		
Motor	Animatics SmartMotors Size 17 & 23	-
Coupling	Beam	-
Ball Screw Leads	5, 10	mm/rev
Position Sensors	Adjustable (3 max) NPN N/O or N/C	-
Stroke Lengths	Standard in 50mm increments to 600 Custom in 1mm increments to 600	mm
Overall Length	Stroke + 182.5 + Motor	mm
Over-Travel	24.5	mm
Unit Mass	1.29 + 0.00414 x (stroke, mm) + (motor mass, kg)	kg
Performance		
Unidirectional Repeatability	3	μm
Bi-directional Repeatability	16	μm
Ball screw Lead Accuracy	0.1/300	mm/mm
Load Rating, Dynamic* (Static)		
Payload Mass	25 or 20 (5 or 10 mm/rev lead)	kg
F. t, Thrust	200 (1140)	N
F.n, Carriage Normal	200 (400)	N
F.st, Carriage Side	200 (400)	N
F.ss, Carriage Side	100 (400)	N
M.a, Carriage Moment**	5 (20)	Nm
M.b, Carriage Moment**	5 (20)	Nm
M.c, Carriage Moment**	5 (20)	Nm

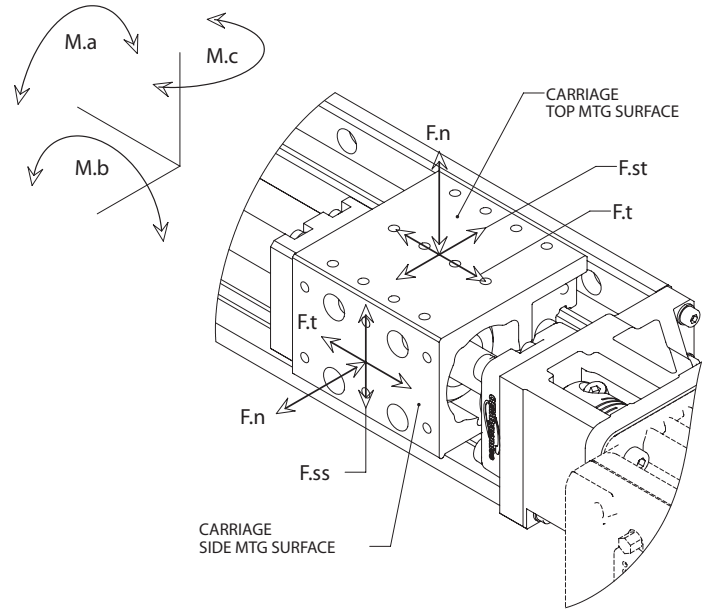
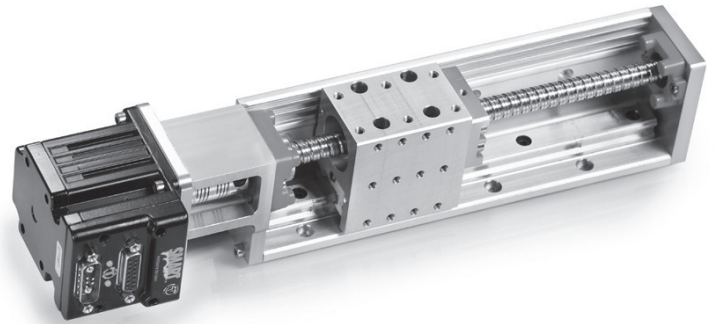

*Based on a basic desired service life of 15,000hr (7.5yrs single shift) @ 167 mm/s and 333mm/s (2000 RPM) average speed at given payload. Consult the factory if your application exceeds these values.

**Moment capacities given about center of carriage mounting surface.

WARNING: Do not exceed these limits

L70 - Maximum Permissible Carriage Velocity

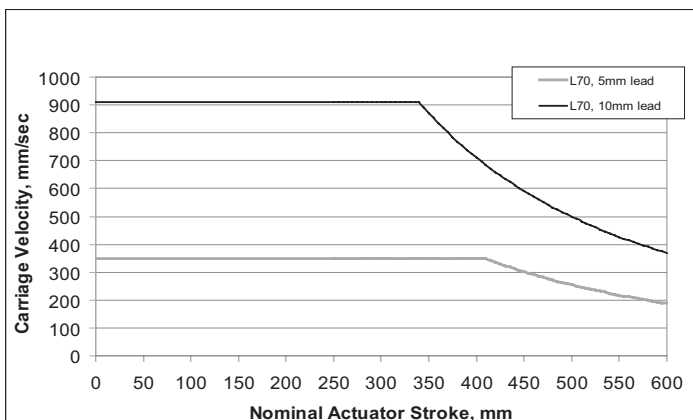

L70 - Maximum Permissible Screw Speed

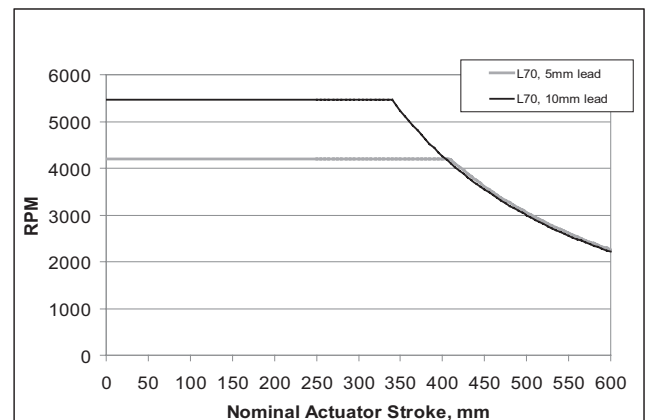

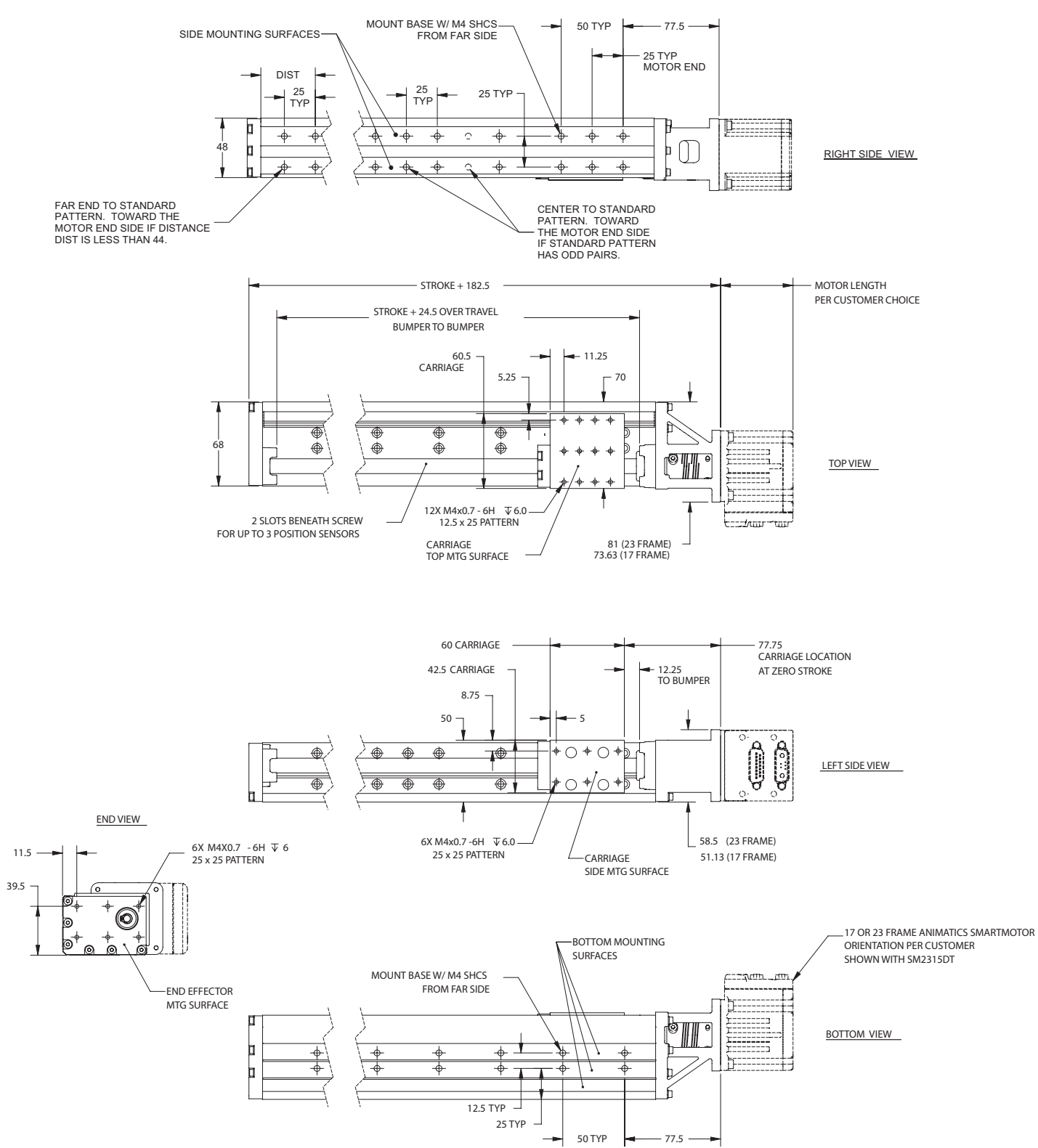

Dimensions in millimeters

Note: For part numbers please refer to our Website at www.oemdynamics.com

Thrust Curve performance data in following section on pages 109-126.